



European
Funds
Smart Growth

European Union
European Regional
Development Fund



COGNOR S.A.
42-360 Poraj, ul. Zielona 26
NIP: 1181234296, REGON 012859760
Oddział Ferrostal Łabędy w Zawierciu
42-400 Zawiercie, ul. Okólna 10
tel. 32 67 100 10 do 14 fax w.201

Zawiercie 22 of January 2018

INVITATION FOR BID No: 1/POIR.01.02.00-00-0160/16/2018

Cognor Spółka Akcyjna Oddział Ferrostal Łabędy w Zawierciu invites the interested parties to submit the bids for manufacturing and supply of spherical, pearlitic cast iron rolls required to implement the Project: „**An Innovative technology for manufacturing new generation profiles for construction industry for housing and industrial requirements**”:

The foregoing Project is the subject-matter of the agreement no **POIR.01.02.00-00-0160/16** for co-financing under the INNOSTAL Sectoral Program comprised in the Operational Program Smart Growth, Actions 1.2. “Sectoral R&D Programs, Priority Axis: “Support for the development of R&D activities in enterprises for the period of 2014-2020”.

1. NAME AND ADDRESS OF THE CONTRACTING PARTY

Cognor S.A. Ferrostal Łabędy Oddział Zawiercie
ul. Okólna 10
42-400 Zawiercie
POLAND

2. Persons authorized to contact the Bidders:

- a. Dorota Wałek email: dwalek@ferrostal.com.pl (commercial and organization issues) tel: +48 510 223 152
- b. Marcin Gliwiński email: mgliwinski@ferrostal.com.pl (technical issues) tel: +48 514 786 705

3. Project name

„**An Innovative technology for manufacturing new generation profiles for construction industry for housing and industrial requirements**”:

COGNOR S.A.
Oddział Ferrostal Łabędy w Zawierciu
PROKURENT
Dyrektor Operacyjny
Marcin Gliwiński

PROKURENT

Krzysztof Gunka



**European
Funds**
Smart Growth

European Union
European Regional
Development Fund



4. Manner of awarding the contract:

The Contract shall be awarded on the competitiveness basis - the most competitive bid will be selected.

5. Date of announcing the Invitation for Bid

22.01.2018

6. Bid submission deadline

26.02.2018

Note: The deadline of bid submission will be met in case the Bid has been submitted before or at the indicated day/time. Any bid submitted at a later time will not be considered.

7. Venue of bid submission

The Bids shall be send by e-mail to the following addresses:

dwalek@ferrostal.com.pl

mgliwinski@ferrostal.com.pl

In the title of e-mail please write inscription: **"Bid related to the Invitation for Bid no. 1/POIR.01.02.00-00-0160/16/2018"**

8. Period of bid validity

The bid validity shall be at least 120 calendar days from the day of its submission.

9. Terms and conditions of participation in the proceedings/ eligibility criteria

An economic operator, whose compliance with the following eligibility criteria has been confirmed based on the provided statements specified in this Invitation for Bid may participate in the proceedings. Non-fulfilment of any of the eligibility criteria shall result in rejection of the respective Bid.

1) Economic operators having personal and/or capital links with the Contracting Party are excluded from the proceedings. Capital or personal links mean any mutual connections between the Contracting Party or persons authorized to enter into obligations on behalf of the Contracting Party or persons performing - on behalf of the Contracting Party – activities associated with preparation and carrying out the proceedings to select the Supplier, and the Supplier, in particular:

- the participation in the company as a partner of a civil or other personal partnership;
- holding of at least 10% of stocks or shares;



- holding the function of a member of a supervisory or managing body, proxy, authorised representative,
- being joined in matrimony, related through kinship or direct affinity, secondary kinship or affinity up to the second degree, or linked through adoption, care or custody.

This criterion will be verified based on the Appendix 1 to this Invitation for Bid.

2) The Bidder shall have suitable human resources capable to perform the subject matter of the Contract and the relevant expertise and experience in the scope covered by the Contract. In particular, the Bidder:

- shall have documentary evidence confirming the experience in manufacturing spherical, pearlitic cast iron rolls for hot rolling.

This criterion will be verified based on the Appendix 4 to this Invitation for Bid. Bidder is also required to submit a reference list describing the due diligence of the aforementioned Supply of rolls.

10. Period of execution of the subject-matter of the Bid

The Supplier of Spherical, pearlitic cast iron rolls shall carry out the works in accordance with the material and financial schedule of the Contract.

The maximum period of delivery of all cast steel rolls shall be 140 days from delivery the contract.

11. Description of the subject-matter of the Invitation for Bid

The subject of the order will be delivery of spherical, pearlitic cast iron rolls, in the amount of 12 pieces for rolling a new profile.

Parameters and requirements for cast steels:

- 1) Material: spherical, pearlitic cast iron. Hardness 470- 490 HB (66-68 Shc)
- 2) As delivered conditions of the rolls: after stress relief annealing, and finally machined as per the drawing, which is in appendix 3.
- 3) Required Acceptance Certificate, Roll Quality Certificate.
- 4) Protected against corrosion and mechanical damage..
- 5) Free of hazardous and radioactive substances..
- 6) After casting, the roll to be ultrasound tested for internal defects and cracks..
- 7) The right to assert claims for hidden defects until the roll has achieved a dead diameter (- 75mm from the diameter of the originally machined roll).



8) Detailed roll specification - see Annex 2.

The Supplier shall deliver the rolls to Cognor SA Ferrostał Łabędy w Zawierciu in damage-free conditions. The transportation of the equipment is done with care, at the cost and risk of the Bidder.

The requirements to be met by trucks used to carry the rolls to the Contracting Party:

1) 1st method

- a) Truck with skip trailer adjustable to the width of roll barrel.
- b) Rolls to be secured by belts..
- c) Rolls to be unloaded by lifting using overhead crane.
- d) Tarpaulin removable from each side wall or roof.

2) 2nd method.

- a) Platform-type trailer equipped with suitable supporting racks to secure the rolls from displacement..

A driver hired to deliver the rolls to the Contracting Party shall be in possession of and use the following Personal Protective Equipment:

- 1) Helmet with strap under chin
- 2) Reflective vest
- 3) Steel toed safety shoes

12. Place of delivery

Cognor SA Ferrostał Łabędy
odział Zawiercie
ul. Okólna 10, 42-400 Zawiercie, POLAND

13. Criteria for bid evaluation

a. The Contracting Party shall apply the following criteria to evaluate the bids (max. score: 100):

Item	Criterion	Verification	Rank/score
------	-----------	--------------	------------



1	Total net price	<p>The score shall be calculated acc. the following formula:</p> $P_n = C_{min} / C_n \times 90 \text{ points.}$ <p>where:</p> <p>P_n- the score for n-Bid</p> <p>C_{min} - the lowest net price out of all prices offered by the Bidders</p> <p>C_n - total net price of n- Bid</p>	max. score: 90
2	Roll delivery time in days (first set)	<p>The score shall be calculated acc. the following formula:</p> $P_n = C_{Zmin} / C_{Zn} \times 10 \text{ points.}$ <p>where:</p> <p>P_n- the score for n-Bid</p> <p>C_{Zmin} – the shortest delivery time out of all delivery times offered by all Bidders. Delivery time less than 60 days will not be considered</p> <p>C_{Zn} – the period of time offered in n- Bid</p>	Max. score: 10

b. The Bid with the highest score calculated as per the table above shall be considered the most competitive one.

c. In case of submitting a bid denominated in foreign currency, the value of such bid shall be converted into Polish zloty (PLN) at the average rate of exchange published by the National Bank of Poland (NBP) as on the day of bid evaluation in order to assure objective comparability of all bids.

d. When selecting the bid, the Contracting Party will follow the rules applicable to the EU's common market, in particular, the principle of: transparency and openness of the proceedings, protection of fair competition, free movement of capital, goods and services, and non-discrimination and equal treatment of all Suppliers on the market

e. All criteria for bid selection should be referred to in the bid. Should the Bidder omit one or more evaluation criteria his bid shall be granted zero score for the respective criterion (criteria).



14. Negotiations with the Bidders

The Contracting Party reserves the right to negotiate with all bidders on the same terms and conditions and with transparency of the proceedings. In such case the Bidders shall provide revised versions of the bids previously submitted.

15. Contract conclusion

The contract will be concluded in the form of a signed contract by both parties, the contract template was attached to this inquiry. The contract will be concluded immediately after selecting the supplier.

16. Special entitlements of the Contracting Party

- 1) The Contracting Party reserves the right to:
 - terminate the proceedings covered by the Invitation for Bid at any time until submission of the bids,
 - close the proceedings without selection of the Supplier,
 - cancel the proceedings both, before and after the selection of the best bid without giving a reason.
- 2) In the foregoing cases, the Supplier shall not be entitled to assert any compensatory claims against the Contracting Party.

17. Additional provisions

- 1) Partial or variant bids may not be submitted within the scope of Request for Quotation.
- 2) The Contracting Party, upon the assessment of the submitted bids, shall select the best bid; the selection shall be confirmed by the respective report.
- 3) If required by the submitted application for co-financing, the bids may be submitted to competent public authority for verification.

18. The Bid may be deemed valid if it contains:

- 1) full name and address of the Bidder, VAT-Reg. No. (NIP) and number of entry into the National Court Register (KRS) or into the Register of Entrepreneurs (EDG),
- 2) net and gross price for performance of supplies and services (the latter value shall comprise VAT).
- 3) date of preparation and validity of the Bid,
- 4) period of execution of the subject-matter of the Bid
- 5) terms and conditions of payment,



**European
Funds**
Smart Growth

European Union
European Regional
Development Fund



- 6) contact data of the person responsible for the Bid,
- 7) signature of the person(s) authorized to issue the Bid or the power of attorney to sign it if the Bid has been signed by the person(s) other than that (those) indicated in the relevant register as representative(s) duly empowered to represent the Bidder,
- 8) signed statements and appendices to this Invitation for Bid:
 - a) Appendix no. 1 – The statement confirming non-existence of personal and capital links (in case of a consortium of R&D companies, each party shall submit a separate statement)
 - b) Appendix no. 4 – The description of experience in manufacturing spherical, pearlitic cast iron rolls for hot rolling.
 - c) Appendix No. 5 - The Supplier's warrants and representations
 - d) excerpt from the register showing the names of the persons authorised to represent the Bidder,

In case of any doubt, the Polish language version is decisive.



**European
Funds**
Smart Growth

European Union
European Regional
Development Fund



Appendix 1.

Supplier/ stamp:

....., (date)

VAT Reg. No. NIP

Company-ID No. REGON

Statement of non-existence of personal and capital links

In response to the Invitation for Bid no **1/POIR.01.02.00-00-0160/16/2018** announced by Cognor SA Ferrostal Łabędy Oddział Zawiercie on 30th of June 2017 for the perform and delivery spherical, pearlitic cast iron rolls, which are necessary for the performance of the project: **„An Innovative technology for manufacturing new generation profiles for construction industry for housing and industrial requirements”**

we, hereby, declare that we do not have any personal or capital links with the Contracting Party. Capital or personal links mean any mutual connections between the Contracting Party or persons authorized to enter into obligations on behalf of the Contracting Party or persons performing - on behalf of the Contracting Party - activities associated with preparation and carrying out the proceedings to select the Supplier, and the Supplier, in particular:

- the participation in the company as a partner of a civil or other personal partnership;
- holding of at least 10% of stocks or shares;
- holding the function of a member of a supervisory or managing body, proxy, authorised representative,
- being joined in matrimony, related through kinship or direct affinity, secondary kinship or affinity up to the second degree, or linked through adoption, care or custody

.....

date and legible signature
of the Supplier's authorized representative



Appendix 2.

Specification of spherical, pearlitic cast iron rolls:

- 1) Middle roll for Trio Stand no III – 4 pcs.**
 - a. Roll diameter Ø 660 mm
 - b. Estimated weight: approx. 4500 kg / pc.
 - c. Numer of passes: 5
 - d. Basic drawing: WB-02/03/011 (Appendix 3)

- 2) Bottom roll for Trio Stand no III – 4 pcs.**
 - a. Roll diameter Ø 605 mm
 - b. Estimated weight: approx. 3900 kg / pc.
 - c. Numer of passes: 5
 - d. Basic drawing: WB-02/03/011 (Appendix 3)

- 3) Top roll for Trio Stand no III – 4 pcs.**
 - a. Roll diameter Ø 605 mm
 - b. Estimated weight: approx. 3900 kg / pc.
 - c. Numer of passes: 5
 - d. Basic drawing: WB-02/03/011 (Appendix 3)



European
Funds
Smart Growth

European Union
European Regional
Development Fund



Appendix 3. Drawing WB-02/03/011:

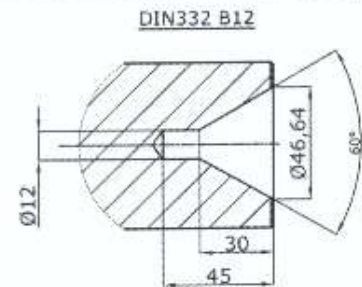
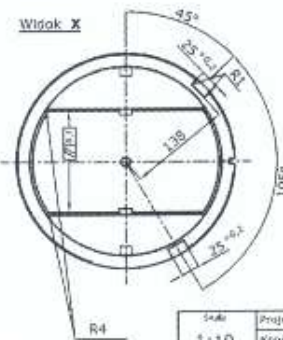
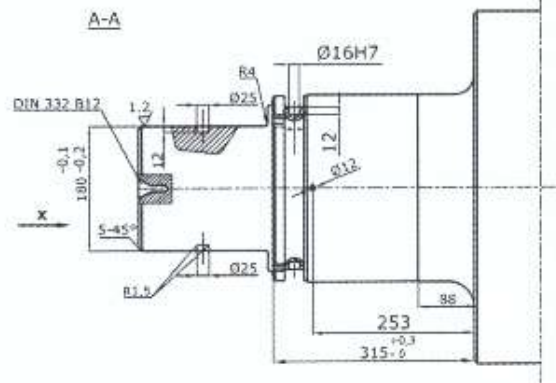
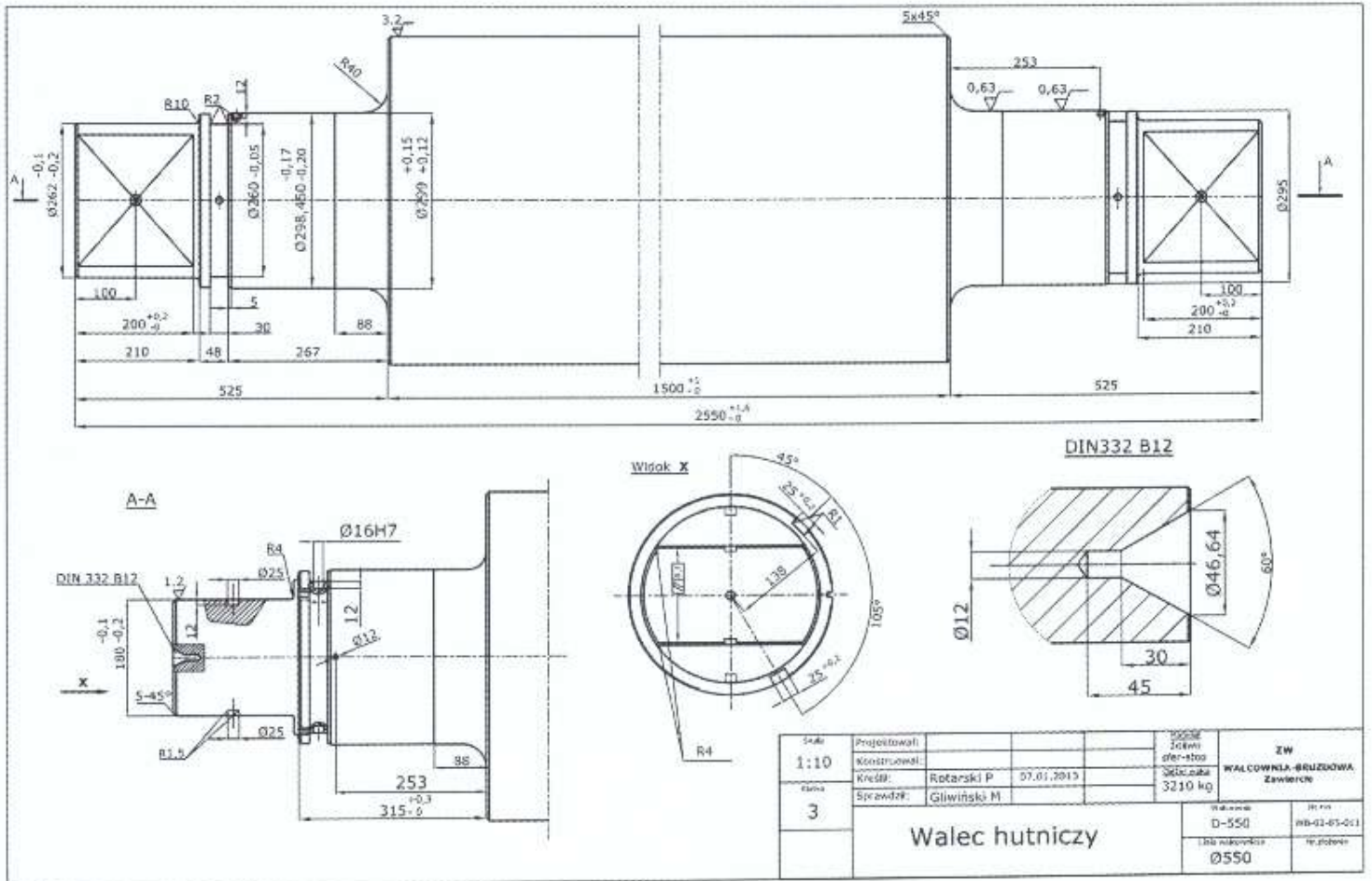

Skala	Projektował				Opis	ZW
1:10	Konstruował				Walcownik	WALCOWNIA BRUZDOWA
	Kreślił	Rotarski P	07.01.2013		3210 kg	Zawierce
3	Sprawdził	Gliwiński M				
Walec hutniczy					Walec	D-550
					Walec	Ø550

Handwritten signature



European Funds
Smart Growth

European Union
European Regional
Development Fund



Appendix 4.

Supplier/ stamp:

....., (date)

VAT Reg. No. NIP.....

Company-ID No.REGON.....

Description of experience of execution and delivery of spherical, pearlitic cast iron rolls casts statically for the production of hot-rolled products

Item	Scope of necessary experience	Documentary evidence of experience held by the Supplier Product quality certificate and reference list (at least 5 deliveries in the last two years)
1.	experience of the production of spherical, pearlitic cast iron rolls casts statically	

.....

Date and legible signature
of the Supplier's authorized representative



**European
Funds**
Smart Growth

European Union
European Regional
Development Fund



Appendix 5.

Supplier/ stamp:

....., (date)

VAT Reg. No. NIP

Company-ID No.REGON

The Supplier's warrants and representations

In response to the Invitation for Bid no **1/POIR.01.02.00-00-0160/16/2018** announced by Cognor SA Ferrostal Łabędy Oddział Zawiercie on 22th of January 2018 for the perform and delivery spherical, pearlitic cast iron rolls, which are necessary for the performance of the project: **„An Innovative technology for manufacturing new generation profiles for construction industry for housing and industrial requirements”**, I/we hereby declare that:

- I/we have read the content of the Invitation for Bid and I/we do not raise any objection. I/we confirm I/we have obtained all information necessary to prepare the Bid;
- I/we accept the assumptions comprised in this Invitation for Bid concerning the scope of the Contract and the requirements contained therein;
- the financial conditions of the Supplier, who is represented by me/us, guarantee the proper performance of the Contract within the specified period;
- the Supplier, who is represented by me/us, is a holder of authorization to perform specific activity (-ies), if such authorization is required by the applicable law;
- I/we, being aware of criminal liability for attestation of untruth provided for in Article 233 of the Act of 6 June 1997 - the Penal Code (JoL of 1997, no. 88 item 553 as amended), hereby declare that the Supplier who is represented by me/us has met all eligibility criteria to participate in the project on the day of bid submission and will continue their meeting throughout the whole duration of Project execution.

.....

Date and legible signature
of the Supplier's authorized representative